

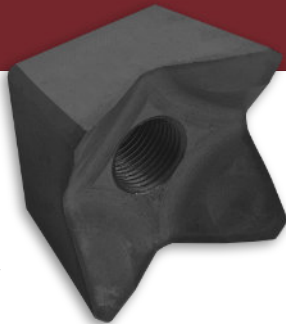

DISC MULCHER TOOTH GUIDE

STEEL TEETH



- Four razor sharp points for max productivity, unmatched aggressiveness and a finer mulch.
- Made from high-grade alloy steel and heat treated.
- Need to be sharpened and rotated regularly to maintain cutting performance.
- Standard on all Virnig V70 Disc Mulchers.
- Manufactured by Quadco®, a leader in the forestry industry.

CARBIDE TEETH



- Sharp, aggressive cutting angle for productive mulching.
- Abrasion-resistant carbide tips for durability in rocky and sandy environments.
- Low maintenance, no sharpening required.
- Install carbide in pairs on the top, bottom or outer edge of the disc. Factory installation not available.
- Manufactured by Quadco®, a leader in the forestry industry.

WHERE SHOULD I INSTALL CARBIDE TEETH ON THE DISC?

Tooth placement is largely based on personal preference, and carbide teeth can be installed anywhere on the disc as long as they're installed in pairs across from each other. Here are Virnig's recommendations:



BOTTOM OUTSIDE



OUTER EDGE

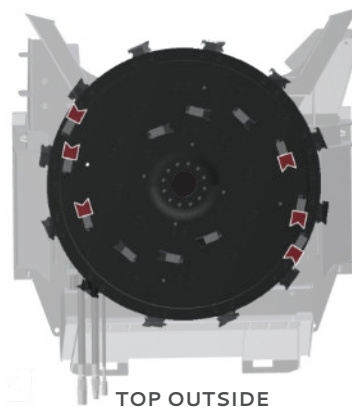

TOP OUTSIDE

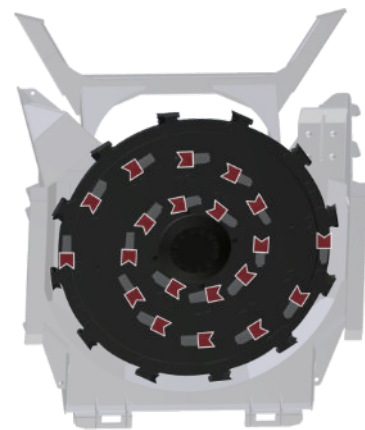

ENTIRE BOTTOM

COMPARISON CHART

TOOTH	MAINTENANCE	PRODUCTIVITY	DURABILITY	FINISH	PRICE
STEEL	High	High	Medium	Best	Low
CARBIDE	Low	Medium	High	Good	High