

SWING BOOM CUTTER



MODEL SERIES

14-20 GPM

SBC

17-30 GPM

SBCNS

SAFETY RULES | OPERATING INSTRUCTIONS | MAINTENANCE PROCEDURES

Record product information below.

	
MODEL	<input type="text"/>
SERIAL	<input type="text"/>
	<input type="text"/>
www.cidattachments.com 336-859-2002	

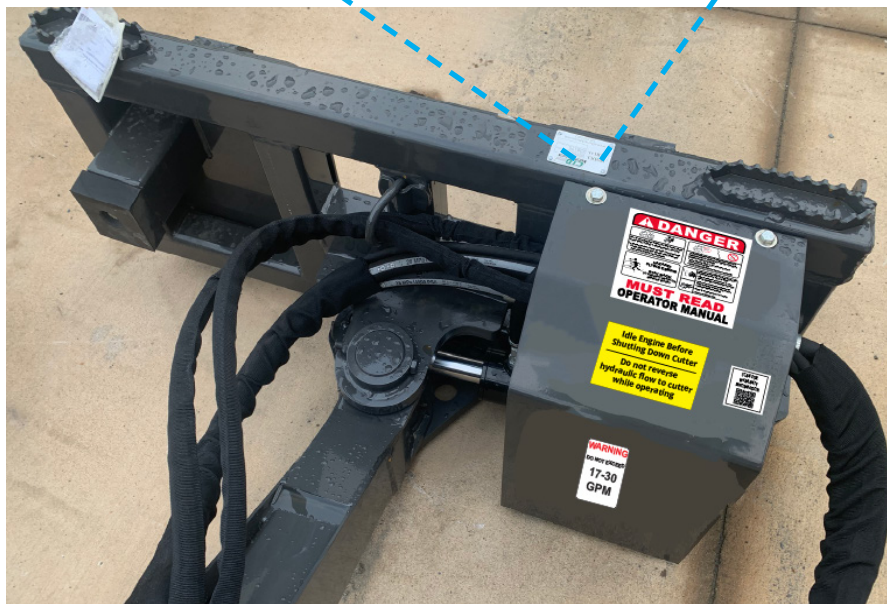

PURCHASE DATE:
DEALER NAME:
ADDRESS:
PHONE NUMBER:

MODEL COMPARISON



Swing Boom Cutter (SBC)

- 14-20 gpm; 4,000 PSI
- 2 blades
- Horizontal Reach: 8'
- Vertical Reach: 16'
- 3" cut capacity
- No case drain required
- Optional universal, 8 pin or 14 pin wiring harness

Piston Motor Swing Boom Cutter (SBCNS)

- 17-30 gpm; 4,000 PSI
- 2 blades
- Horizontal Reach: 8'
- Vertical Reach: 16'
- 4" cut capacity
- Case drain required
- Optional universal, 8 pin or 14 pin wiring harness

Register this product at www.cidattachments.com.

	NOTICE
	This manual is part of the machine and should remain with the machine at all times.
	Store this manual in the document canister attached to this machine.

	SCAN TO VIEW OWNER'S MANUAL
SWING BOOM CUTTER	 SBCSBCSMAN01

Copyright © 2021 Construction Implements Depot, Inc. All Rights Reserved. This manual may not be reproduced or copied, in part or in whole without written permission from CID, Inc.

SBCSBCSMAN01 / FIRST EDITION / AUGUST 2021

TABLE OF CONTENTS

LETTER TO OWNER	6
------------------------------	---

SECTION 2 SAFETY INFORMATION

2.1 Introduction.....	8
2.2 Safety Symbols.....	8-10
2.3 Safety Decals.....	11-13
2.4 Skid Steer Tractor Requirements.....	14
2.5 General Safety Instructions.....	15

SECTION 3 OPERATING PROCEDURES

3.1 Unpacking Your Brush Cutter.....	17
3.2 Pre-Operating Checklist.....	17
3.3 Connecting Brush Cutter To Skid Steer Tractor.....	18-19
3.4 Connecting Electrical Harness.....	19
3.5 Paddle Controller Setup.....	20
3.6 Swing Boom Cutter Controls.....	21-22
3.7 First Time Use.....	23
3.8 Cutting Operations.....	24-25

SECTION 4 MAINTENANCE PROCEDURES

4.1	Maintenance Overview.....	26-27
4.2	Maintenance Schedule.....	28
4.3	Storage Tips.....	29
4.4	Blade Holder Removal.....	29-30
4.5	Blade Holder Installation.....	31
4.6	Blade Removal Procedures.....	31-32
4.7	Blade Installation Procedures.....	33
4.8	Drive Bearing Housing Maintenance.....	34-35
4.9	Shear Bolt Replacement.....	35
4.10	Hydraulic Flow Diagram.....	36
4.11	Torque Specifications Table.....	37

SECTION 5 TROUBLESHOOTING

5.1	Troubleshooting Chart.....	39
-----	----------------------------	----

SECTION 6 SPECIFICATIONS

6.1	Specification Chart.....	41
-----	--------------------------	----

SECTION 7 PARTS INFORMATION

7.1	Parts Assembly Diagrams.....	43-46
7.2	Electrical Drawings.....	47

SECTION 8 WARRANTY INFORMATION

8.1	Limited Warranty Statement.....	49
8.2	Warranty Service Procedure.....	50

MAINTENANCE LOGS.....	52-53
------------------------------	--------------

SAFETY ACKNOWLEDGEMENT FORMS.....	54-56
--	--------------

THANK YOU

Dear Owner:

We appreciate your business and thank you for choosing Construction Implements Depot, Inc. as your provider of quality skid steer attachments. We are committed to providing you with a heavy duty product that will provide years of satisfaction and safe operation.

This manual will provide instructions on how to safely operate and maintain the Swing Boom Brush Cutter. All users must read and understand this manual before operating this machine. Upon reading this manual, all users should sign the "Safety Acknowledgement Form" at the end of this manual. Store this manual in the document canister attached to this machine.

Please record your model and dealer information on the inside front cover. You will be asked to provide this information when ordering parts or requesting service. If you need more information on this product, contact your local dealer or visit www.cidattachments.com.

Sincerely,

The CID Team
Construction Implements Depot, Inc.



A decorative border made of red diagonal hatching surrounds the entire page. The text is centered within this border.

SECTION 2

SAFETY INFORMATION

2.1 Introduction

The following terms are used interchangeably throughout this manual.

Term	Alternate Terms Used
Swing Boom Brush Cutter	implement, attachment, product, machine, brush cutter, cutter
Skid Steer	skid steer loader, skid steer tractor, loader, prime mover
Operator	user, personnel

The **Swing Boom Brush Cutter** is designed and manufactured with safety in mind. However, improper use and operator error can result in death or serious injury. It is important that you read and fully understand the safety instructions and operating procedures in this manual before operating this brush cutter. Accident prevention is a combination of good judgement, common sense, awareness and proper training!

BEFORE you operate this Brush Cutter:

1. KNOW how to safely operate your skid steer loader.
2. READ and UNDERSTAND the safety instructions and operating procedures contained in this manual.
3. ACKNOWLEDGE your understanding of all safety instructions presented in this manual by signing the "Safety Acknowledgement Form" at the end of this manual.

Although every effort has been made to ensure a safe product, every possible circumstance that could pose a potential hazard cannot be anticipated. The safety warnings in this manual and on this product, are therefore not all-inclusive.

In addition to the safety messages presented in this section, you must also read and understand the safety messages presented in the other sections of this manual.

2.2 Safety Symbols

This manual and decals on this machine use safety symbols, pictograms and color coded signal words to alert you to potential hazards that may cause death or severe injury if a safety instruction is ignored. Become familiar with the following symbols.



SAFETY ALERT SYMBOL - This symbol is used to alert you to potential personal injury hazards. Obey all safety messages that follow this symbol to avoid possible injury or death.

Hazard Classifications

Hazards are identified by the "Safety Alert Symbol" and followed by the signal word "DANGER", "WARNING", or "CAUTION".



Indicates an imminently hazardous situation which, if not avoided, will result in death or serious injury. This signal word is limited to the most extreme situations.



Indicates a potentially hazardous situation which, if not avoided, could result in death or serious injury.



Indicates a potentially hazardous situation which, if not avoided, may result in minor or moderate injury.



Indicates a situation which may cause damage to equipment or property. Messages are not related to personal injury.









Indicates specific safety-related instructions or procedures.

2.2 Safety Symbols Cont.

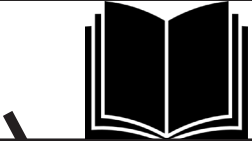
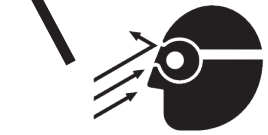
Safety Pictograms

Pictograms are graphic symbols meant to alert you of a potential hazard. Read and understand the hazard description for each of these symbols.

Pictogram	Description
	PINCH HAZARD: Keep clear of skid steer and brush cutter machine to prevent death or serious injury from pinching of moving parts.
	FLYING DEBRIS HAZARD: ONLY operate this machine using a skid steer that has a shatter proof cab to prevent death or serious injury from objects being thrown.
	OPERATING MANUAL: Operators must read and understand the safety instructions in the operating manual to prevent death or serious injury.
	EYE PROTECTION & CARDBOARD: Operators and Maintenance personnel must wear proper eye protection and use cardboard or wood to investigate hydraulic leaks to prevent death or serious injury from being injected with high pressure hydraulic fluid.
	HIGH PRESSURE FLUID INJECTION HAZARD: Operators and Maintenance personnel must not place fingers or hands directly over a hydraulic leak to prevent death or serious injury from being injected with high pressure hydraulic fluid.
	NO BYSTANDERS: DO NOT operate this machine near bystanders. Bystanders must stay back at least 300 feet from the machine to prevent death or injury from objects being thrown.
	CRUSH HAZARD: DO NOT place any part of the body under the machine or skid steer arms to prevent death or serious injury from being crushed .

2.3 Safety Decals

The safety decals affixed to this machine are in place to keep you safe. DO NOT ignore these decals. Read and understand each decal's safety message. The following safety decals are affixed to this machine:

1



2



MUST READ OPERATOR MANUAL

3



4

DANGER STAY BACK

Figure 2.3 Safety Decal Locations

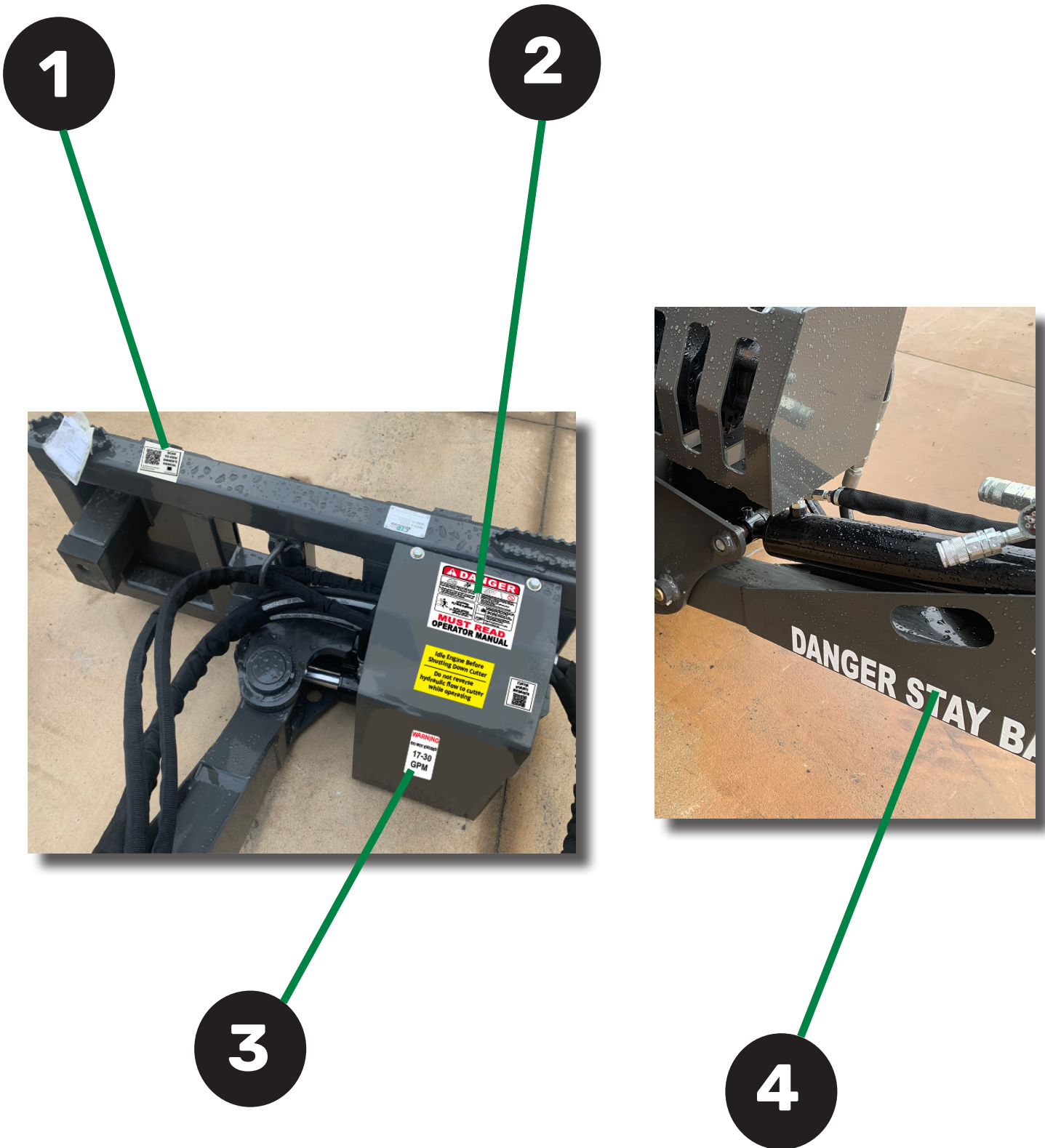

Figure 2.3 Safety Decal Locations Cont.

REF	DESCRIPTION	QTY
1	SCAN TO VIEW OWNER'S MANUAL QRS CODE STICKER	1
2	COMBO DANGER WARNING LABEL PINCH HAZARD, HIGH PRESSURE FLUID HAZARD, FLYING DEBRIS HAZARD, * replaces older 4 sticker labels	1
3	WARNING DO NOT EXCEED GPM LABEL **WHEN ORDERING CHOOSE THE PROPER DECAL FOR YOUR MODEL	1
4	DANGER STAY BACK LABEL ** THERE ARE TWO DECALS left side front and right side front of swing boom	2

Safety Instructions

- ⚠ Decals must be kept clean and legible at all times.
- ⚠ Operators must inspect the machine for safety decals.
- ⚠ Replace missing, worn or damaged decals immediately.
- ⚠ Use care when cleaning the machine. When using a hot pressure washer make sure water jet is not too close to the decal as this may cause the decal to peel.
- ⚠ When replacing parts, be sure safety decals are in place prior to using the machine.
- ⚠ Make sure metal surface is dry and free of dirt and grease before applying a new decal to this machine.
- ⚠ Contact your local dealer to order replacement decals.

2.4 Skid Steer Loader Requirements

CAUTION

Ensure your skid steer loader is in good operating condition. Follow the operating instructions found in your skid steer operator's manual. Failure to do so could result in minor or moderate injury.



The Swing Boom Brush Cutter should only be used on Skid Steer Loader's that meet the following requirements:

- **Minimum Lift Capacity = 1,800 lb**
- **Minimum Weight w/ Bucket Removed = 6,500 lb**
- **Impact Resistant Windshield and Cab Side Windows**
- **High Flow Auxiliary System**
- **Engine Horsepower Rating = 65 HP**
- **12V Auxiliary Electrical Connector** (not required if using optional controller)

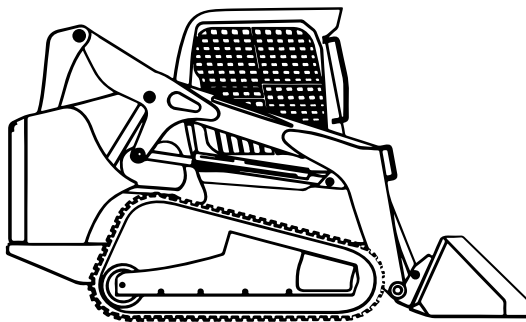

A skid steer equipped with tracks (COMPACT TRACK LOADER) will provide superior stability in this application.

2.5 General Safety Instructions

Below are general safety instructions that relate to the overall operation and maintenance of this machine. It is important that you read and understand each message to prevent serious injury or death.

- ⚠ ALWAYS watch for overhead power lines.
- ⚠ DO NOT place hands or feet under mower deck while blades are spinning.
- ⚠ NEVER operate this brush cutter when bystanders are within 300 feet of your work area. Flying debris could cause serious injury or death.
- ⚠ NEVER position your body or limbs under an unsupported cutter deck.
- ⚠ DO NOT allow this machine to contact buildings, utilities, large rocks or tree stumps or you may lose control of the skid steer loader.
- ⚠ NEVER use drugs or alcoholic beverages while operating or servicing this machine.
- ⚠ ALWAYS operate this attachment during daylight or well-lit areas.
- ⚠ Install this brush cutter on a skid steer loader equipped with a thermoplastic polycarbonate door panel and side panels only.
- ⚠ To prevent the skid steer loader and implement from rolling forward, stop the engine and set the parking brake when exiting the skid steer loader.
- ⚠ Inspect implement for missing hardware prior to using this machine.
- ⚠ DO NOT allow children to play on or around this equipment at any time. Store this implement in an area not frequented by children.
- ⚠ ALWAYS wear the proper personal protection equipment while operating or servicing this machine. NEVER operate or service this machine with bare feet, sandals, or other light footwear.
- ⚠ ALWAYS wear work gloves when handling cutter blades as they are often very sharp.
- ⚠ ALWAYS use eye protection while operating or servicing this machine.
- ⚠ DO NOT speed! Keep your driving speed between 2 and 5 mph.

SECTION 3

OPERATING PROCEDURES

3.1 Unpacking Your Brush Cutter

Your attachment arrives from the factory strapped to a wood pallet, and requires no final assembly. Use a pair of tin snips to remove the steel strapping.

CAUTION

Shipping straps are under great tension, and could lash out uncontrollably when cut causing injuries to your body. Keep bystanders away and wear safety glasses and gloves while removing the straps.

3.2 Pre-Operating Checklist

Pre-Operating Checklist	
	Task
<input type="checkbox"/>	Swing Boom Cutter is securely attached to the skid steer loader.
<input type="checkbox"/>	Hydraulic hoses are connected and locked to the skid steer hydraulic couplers with no signs of hydraulic oil leaks present.
<input type="checkbox"/>	Blades are in working condition and securely attached to the blade holder and all bolts and nuts are tight.
<input type="checkbox"/>	Safety labels are present and legible.
<input type="checkbox"/>	No material, ropes, wire, etc. is obstructing the blades and blade holder assembly.
<input type="checkbox"/>	The area of operation is clear of bystanders and any obstacles that could damage the equipment or cause injury to the operator.
<input type="checkbox"/>	The operator is of good health and not under the influence of any mind altering substances or alcohol.

3.3 Connecting Brush Cutter

Consult your skid steer operator's manual for specific instructions on how to connect your brush cutter to your skid steer loader.

General Attachment Method

1. Make sure the hydraulic lines are clear from the front side of the brush cutter's attachment plate and that the locking pins on the skid steer mounting plate are retracted.
2. Drive forward and place top of skid steer mounting plate under the attachment mounting flange. See Figure 3.3 below.
3. Slowly raise and tilt back the skid steer mounting plate until the brush cutter attachment plate rests flat against the skid steer mounting plate.
4. Activate your skid steer's lever lock switch to engage and lock the pins into the flange slots of the brush cutter's attachment plate. If your skid steer does not have this switch, push the latch handles down until you can see the lock pins extend into the attachment flange.

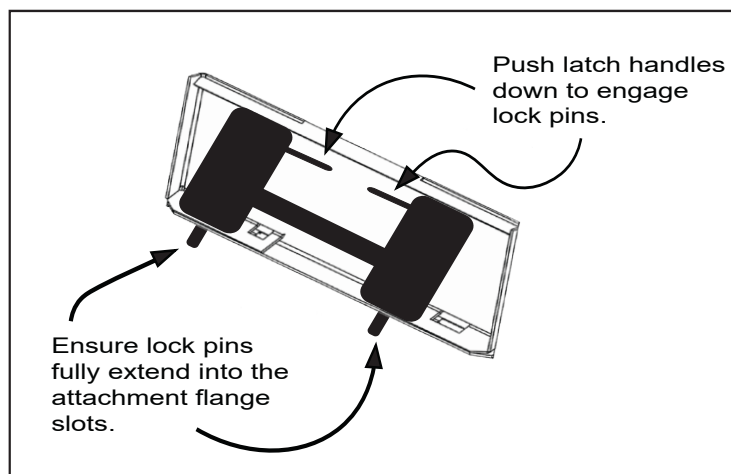
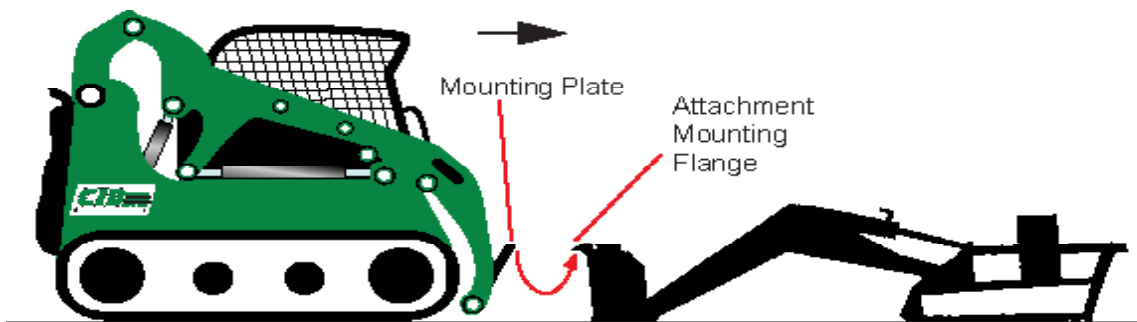

Figure 3.3 Skid Steer Mounting Plate to Attachment Mounting Flange

3.3 Connecting Brush Cutter Cont.

NOTICE

To keep contaminants from entering the hydraulic system; wipe off any dirt or dust from the male or female hydraulic flat face couplers with a clean rag before attaching hoses.

5. Connect the attachment hydraulic hoses and the case drain hose (SBCNS model only) to the auxiliary supply couplers located on your skid steer loader lift arm.

NOTICE

Check that the hydraulic hoses are locked into the skid steer couplers before starting the cutter.

! WARNING

DO NOT operate this machine if you can see the cutter blade while seated in the operator's seat. If you can see the cutter blade, the back of the cutter is raised T00 HIGH. Lower the cutter deck to avoid from being struck by flying debris.

3.4 Connecting Electrical Harness

Connect the electrical attachment harness from the swing boom cutter to the electrical bulkhead connector mounted on the skid steer loader arm. A *universal, 7, 8, or 14 pin* pigtail harness adapter is available to make this connection. See Electrical Drawings, on page 47 for more information.

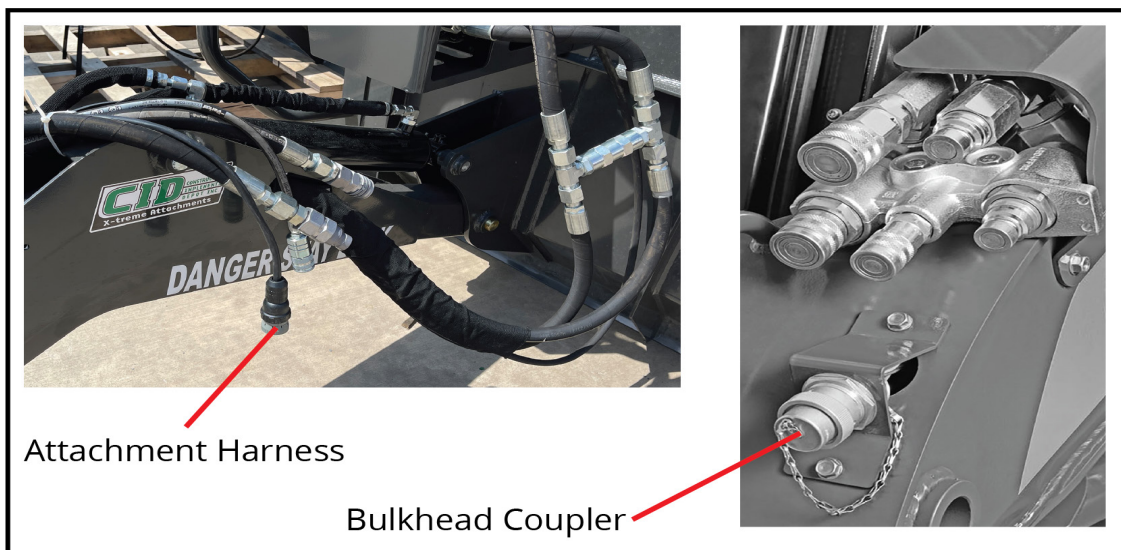

3.5 Paddle Controller Installation

If your skid steer **does not** have an auxiliary electrical connector, you will use the paddle controller to control the tilt and swing functions of the swing boom cutter.

NOTICE

To prevent possible equipment damage, it is recommended the paddle controller be installed by a qualified technician who is familiar with your skid steer's electrical system.

To Install Paddle Controller:

1. Place the paddle controller on the seat inside the skid steer cab and route the power source cable that extends from the left side of the paddle controller to a point where the red wire with fuse can be connected to the skid steer's operator presence system, and the black wire connected to the skid steer's grounding system.

WARNING

The paddle controller must connect to the skid steer's *operator presence system* to avoid serious injury or death. This system will disconnect power to the attachment when the operator restraint bar is raised or when the operator rises from the seat.

Do not connect the controller directly to the skid steer's battery or other source that is energized all the time. You could be killed or severely injured if a control switch is accidentally bumped while exiting the skid steer cab.

2. Route the control cable that extends from the right side of the controller box through the cab and up to the back of the loader pivot arm, then down the arm to a point near the hydraulic couplers. *Note: Secure this cable using plastic cable ties along the inside of the loader arm to prevent cable from being snagged by tree branches or other debris.*
3. Check that the cable is free of tension when raising and lowering the skid steer arms.
4. Route the Velcro lap strap through the metal brackets at the bottom of the paddle controller, then secure paddle controller to your leg.

WARNING

To avoid unwanted attachment movement that may result in serious injury, remove paddle controller from lap when exiting the skid steer loader.

3.6 Swing Boom Cutter Controls

To operate the swing boom controls the skid steer's auxiliary hydraulic system must be activated. To swing or tilt the cutter head you will use your skid steer's auxiliary controller or the paddle controller attached to your leg.



**Typical Skid Steer Auxiliary
Electric Controller**



Paddle Controller

NOTE: When using the controls to swing the boom or tilt the cutter head, the cutter speed will slow down. The cutter will resume its normal operating speed once the swing or tilt action has stopped.

Swing Function

The Swing Boom Cutter rotates 90° to the right of the skid steer's mounting point. Use the LEFT or RIGHT buttons on the controllers to stop the boom anywhere between 0° and 90°.



To prevent Serious injury or death from pinching, keep all persons and objects away from the boom while it is operating.

3.6 Swing Boom Cutter Controls Cont.

! CAUTION

With the boom swung at 90°, you must be aware of any obstacles and terrain in front of the cutter head and in front of your skid steer. Lack of awareness may cause the skid steer loader or swing boom cutter to strike obstacles that may result in serious injury or damage to equipment.

Tilt Function

The Swing Boom Cutter deck can tilt up 90° from the horizontal position and tilt down 35° from the horizontal position. Use the UP and DOWN buttons on your skid steer's auxiliary electric controller, or paddle controller to tilt the cutter head. The tilt function is used for cutting on sloped terrain surfaces.

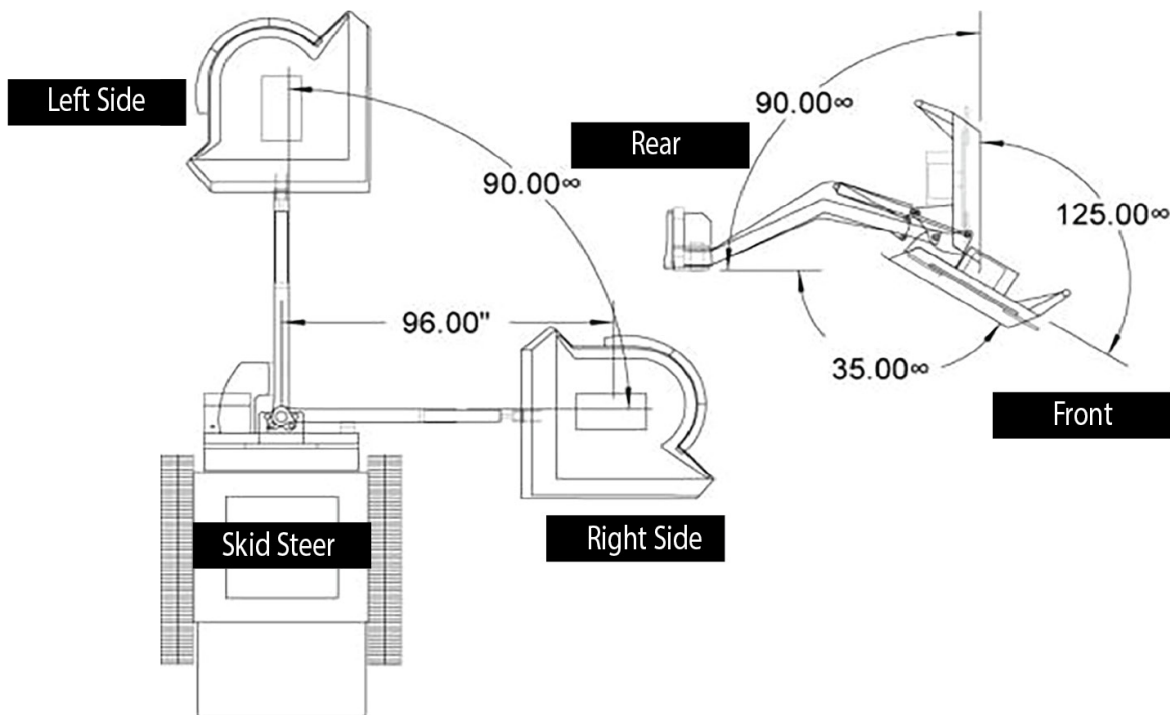

3.7 First Time Use Procedure

NOTICE

Before operating the brush cutter, check the skid steer's hydraulic oil level and add oil if necessary.

If you are operating the *Piston Motor Swing Boom Cutter (SBCNS)* ensure the case drain hose is properly attached to the prime mover's case drain connection. **DO NOT** operate this attachment **WITHOUT** the case drain hose attached. Excessive hydraulic pressure will blow out the seals.

Ensure that hydraulic hoses are securely locked to the skid steer hydraulic couplers before starting the brush cutter.

After starting skid steer, lift attachment 36 inches off the ground surface:

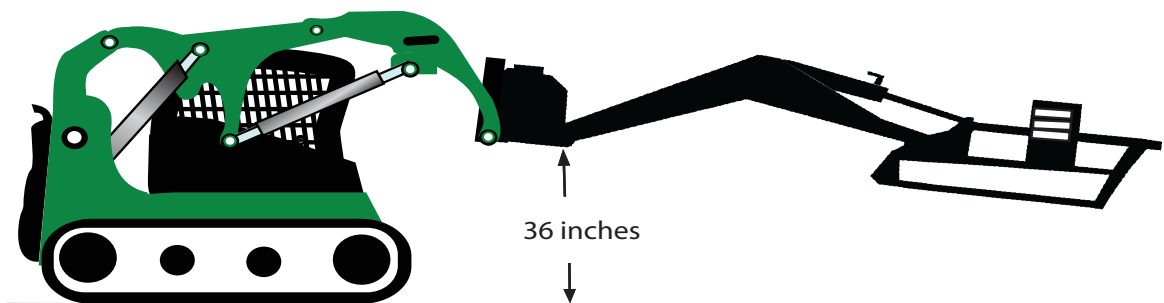

1. With the skid steer engine RPMs just above idle, activate the skid steer's auxiliary hydraulic system.
2. Swing the boom to the right using the skid steer's auxiliary electrical controller, or by holding down the RT button on the paddle controller.
3. Tilt the cutter up by holding down the UP button on the paddle controller. Then tilt in the opposite direction by holding down the DOWN button.
4. Swing the boom to the straightforward position and tilt the cutter to the level position using the buttons on the paddle controller.
5. Allow the cutter to run for 30 seconds to purge air from the system, then turn off hydraulic flow to the brush cutter and allow it to come to a complete stop.
6. Lower the brush cutter to the ground, set parking brake, shut off the skid steer's engine and exit the operator's compartment.
7. Check the skid steer's hydraulic oil level, add oil if necessary.

3.8 Cutting Operations

General Operating Tips

- LEARN what the cutter head looks like in a level position when you are seated in the skid steer. Knowing what a level cutter head looks like will prevent you from damaging the cutter blades if you cut too close to the ground.
- SLOW down the skid steer if the engine “bogs” down or if the cutter speed is too slow because of too much load.
- LISTEN and FEEL for any strange vibrations or noises. If you feel a bad vibration when cutting, slow the skid steer down and see if the vibration stops. If not, stop the brush cutter and investigate the cause. Refer to the “Troubleshooting Chart” on page 39 of this manual.
- ALWAYS be aware of your surroundings and pay attention to what obstacles and terrain are in front of you. When the cutter is swung 90° you have a much larger path to be aware of.
- NEVER use the cutter to push, pull, lift or move any type of vehicle or object.
- DO NOT use the cutter to “push” down trees. The swing boom cutter can cut down small trees up to 3 inches in diameter. To cut down small trees place the tree trunk inside the “V-NOTCH” at the front of the cutter deck.

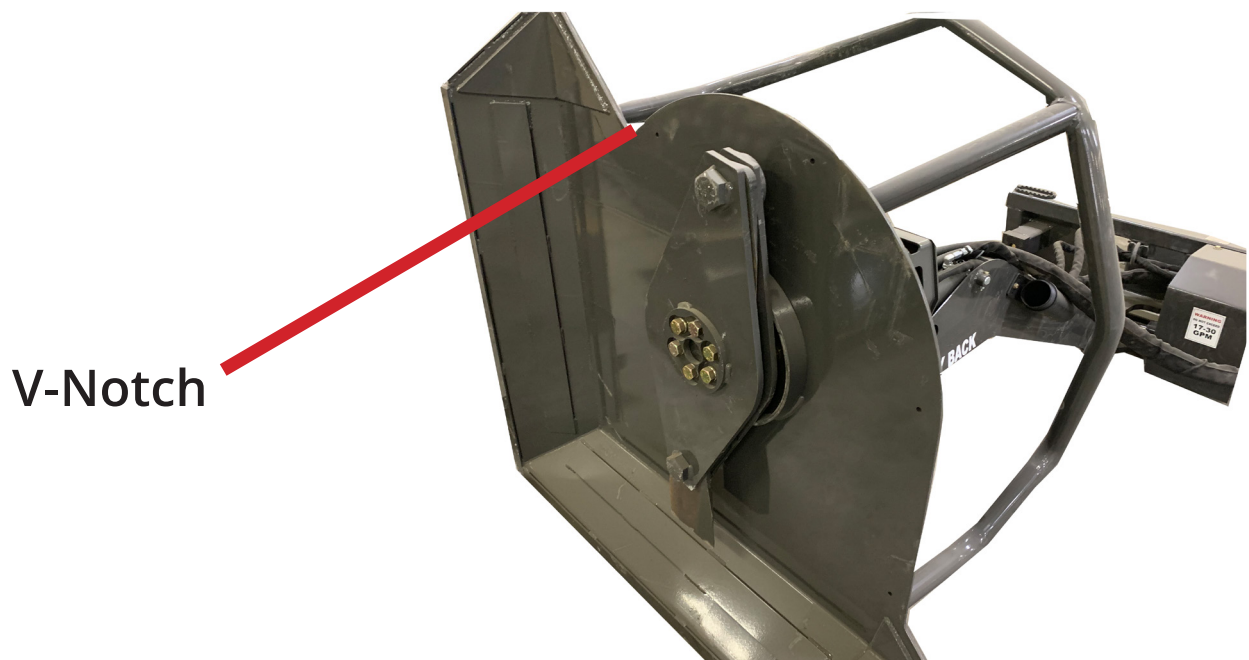

3.8 Cutting Operations Cont.

Vertical Cutting

Your Swing Boom Cutter is designed to cut vegetation with the cutter head in the vertical position. Vertical cuts are great for widening pathways, roadways and other access areas.

WARNING

Vertical cutting can disperse flying debris over a large area and could cause death or serious injury to bystanders. Do not operate the cutter when bystanders are within 300' of this machine.

WARNING

Use care when operating on uneven terrain or any type of sloped surface. Keep the cutter low to the ground to avoid a roll over accident that could result in serious injury or death.

DANGER

To prevent from being electrocuted and killed, watch out for overhead electrical lines when operating the cutter boom.

To cut vertically:

1. Raise the skid steer loader arms.
2. Tilt the cutter head to the vertical position.
3. Swing the boom to the right to the desired cutting position.
4. Raise and lower the skid steer loader arms to trim around branches.

SECTION 4

MAINTENANCE PROCEDURES

4.1 Maintenance Overview

The maintenance procedures described in this manual should only be carried out by qualified mechanics who have been trained to repair this machine.







Some procedures require special tools and skills to complete. DO NOT attempt to repair or perform service work on this machine unless you have the skills and tools to do so. Contact your local dealer for maintenance and repair services.

NOTICE

Improper maintenance or modifications to the design or performance of this machine will void the warranty. ONLY use genuine CID replacement parts on this machine.

Safety Instructions

Obey the following safety instructions when servicing or repairing this machine.

-  Wear proper Personal Protective Equipment (PPE) while working on this machine, which may include safety glasses, hard hats, steel toe boots, gloves, etc.
-  Wear a welding helmet when welding to protect your eyes, face and neck from flash burn, ultra-violet radiation and heat.
-  Ensure all jack stands, lifts and hoists are in good working condition and have the rated load capacity to support the load.
-  If servicing is performed while the brush cutter is attached to the skid steer, turn engine off, set parking brake and chock wheels to prevent skid steer from moving.
-  Only perform service work in a well-lit area.
-  Allow the machine to cool down before servicing this machine. Hot oils can burn your skin.
-  NEVER work under an unsupported cutter deck.

4.2 Maintenance Schedule

This brush cutter attachment will provide years of dependable service if routine maintenance procedures are performed. The maintenance tasks listed below are based on normal operating conditions. More frequent maintenance may be necessary with intense use or when operating in adverse environmental conditions.

MAINTENANCE TASK	BEFORE EACH USE	WEEKLY	YEARLY
Check skid steer loader hydraulic fluid level. Add fluid as necessary.	X		
Check that all fasteners (nuts, bolts,, washers, pins, keepers) are in place. Tighten as necessary. (See Bolt Torque Table on page 37)	X		
Inspect and replace any worn, torn, or missing safety decals.	X		
Inspect hydraulic plumbing (hoses and connectors) for damage or leakage. Repair or replace hydraulic items as necessary.	X		
Check condition of cutter blades. Sharpen or replace as necessary.	X	X	X
Check oil level in bearing housing. Add fluid as necessary.		X	
Change oil in bearing housing. * Change oil after 50 hours of first time use, then every 1000 hrs or yearly.			X
Wash Brush Cutter		X	
Check brush cutter for major scratches and dings.Sand and repaint these areas to prevent rust damage. *Use a paint formulated for farm equipment which can be found at your local hardware store.			X
Lubricate all pivot joints.			X

Maintenance Log

Document all maintenance and service activities performed on this brush cutter using the maintenance log included at the end of this manual.

4.3 Storage Tips

To get years of quality use out of your brush cutter, follow these storage tips:



Ensure brush cutter is free of debris, dirt, grime and grease.

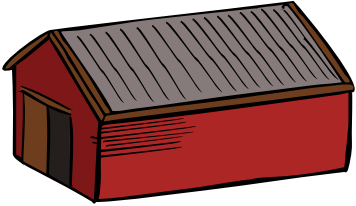

Store your brush cutter in a dry shed or garage.



When storing your brush cutter for the season, cover with a weather proof tarp to protect it from the elements.



4.4 Blade Holder Removal

WARNING

To avoid an accident that could result in death or serious injury, **NEVER** place your body under an unsupported cutter deck when servicing this brush cutter.

ONLY service the brush cutter on stable, even terrain. **NEVER** park on sloped terrain to avoid being struck and killed or seriously injured by the unexpected rolling or movement of the skid steer.

NOTICE

ALWAYS release the hydraulic system pressure from the auxiliary hydraulic circuit prior to removing the blade holder.

4.4 Blade Holder Removal Cont.

Removal Procedure

CAUTION

When performing this procedure alone, rig a pair of choker slings through the blade holder and connect to an overhead hoist. This will prevent the blade holder from falling on to you causing injury to your body.

1. Place the swing boom attachment below an overhead hoist if available.
2. Position the cutter deck in a vertical position to gain access to the blade holder (see figure 4.4a below).
3. If swing boom cutter is attached to skid steer, stop the hydraulic flow circuit, turn off skid steer engine, set parking brake, and chock skid steer wheels.
4. Rig a pair of choker slings through the blade holder and connect to an overhead hoist. Keep tension on the slings to prevent the blade holder from falling once the bolts are removed.
5. Remove the **six 3/4 inch bolts** that secure the holder to the gearbox shaft. If the blade holder fails to separate, use a wedge breaker tool to help separate the blade holder from the gearbox flange.
6. Use the hoist to place the blade holder on a suitable work surface.

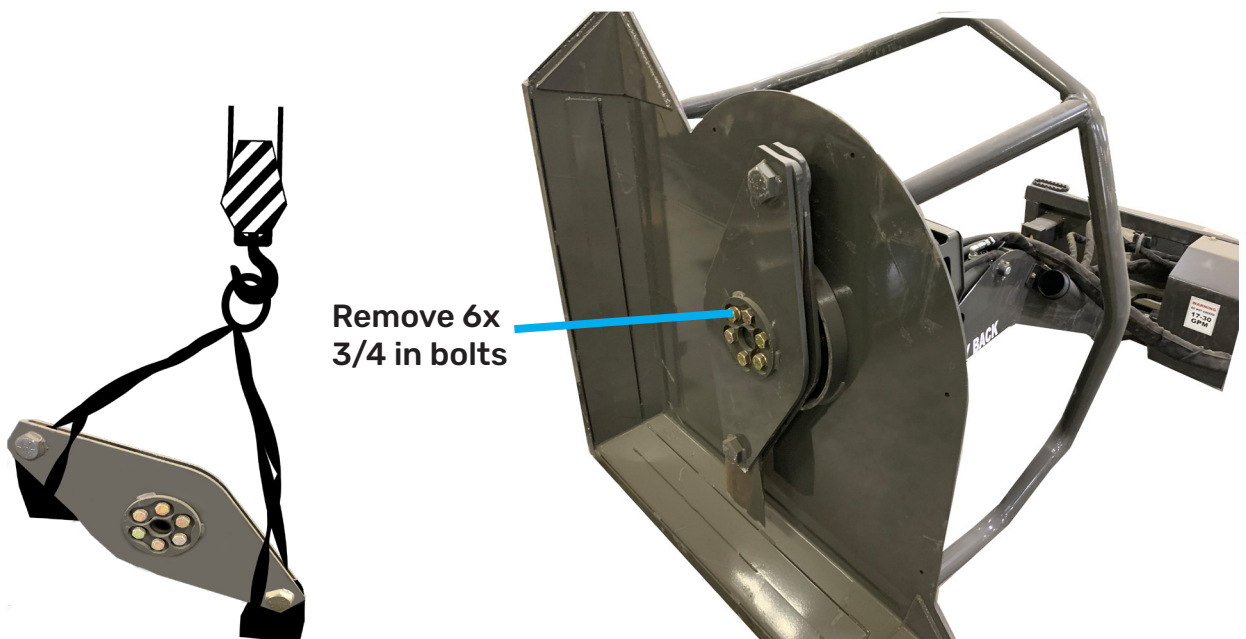

Figure 4.4a Blade Holder and Sling System

4.5 Blade Holder Installation

Installation Procedure

NOTICE

Use a hoist, lift table or forklift to support the blade holder during installation.

1. Align the hole in the blade holder to the gearbox shaft and fully seat the holder onto the shaft.
2. Tap the blade holder with a rubber hammer to ensure full engagement. The blade holder must be properly aligned and seated on the gearbox shaft splines before proceeding to the next step.
3. Install the six 3/4 inch bolts and torque to the value shown in the Torque Table on page 37.

4.6 Blade Removal

NOTICE

This procedure requires special tools and skills. **DO NOT** attempt to remove or sharpen blades if you do not have the tools or skills. Take your brush cutter to your local dealer for blade services.

CAUTION

Cutter blades are sharp and could cut you if mishandled. **ALWAYS** wear protective gloves, footwear and safety glasses when handling cutter blades.

Blade Removal Procedure

1. Remove the blade holder as described in Section 4.4 of this manual.
2. Use a cutting torch or a grinder with a cut off wheel to remove the weld bead around the bolt head. (see Figure 4.6a on next page).

CAUTION

Wear proper protective equipment while using a cutting torch and grinder tool to prevent injuries from flying hot metal pieces. **DO NOT** use a cutting torch during windy conditions nor near dry vegetation to prevent a catastrophic brush fire.

3. Drive the bolt shank from the blade and blade holder, being careful not to let the blade fall onto your feet (repeat steps 2 and 3 for the second bolt).

4.6 Blade Removal Cont.

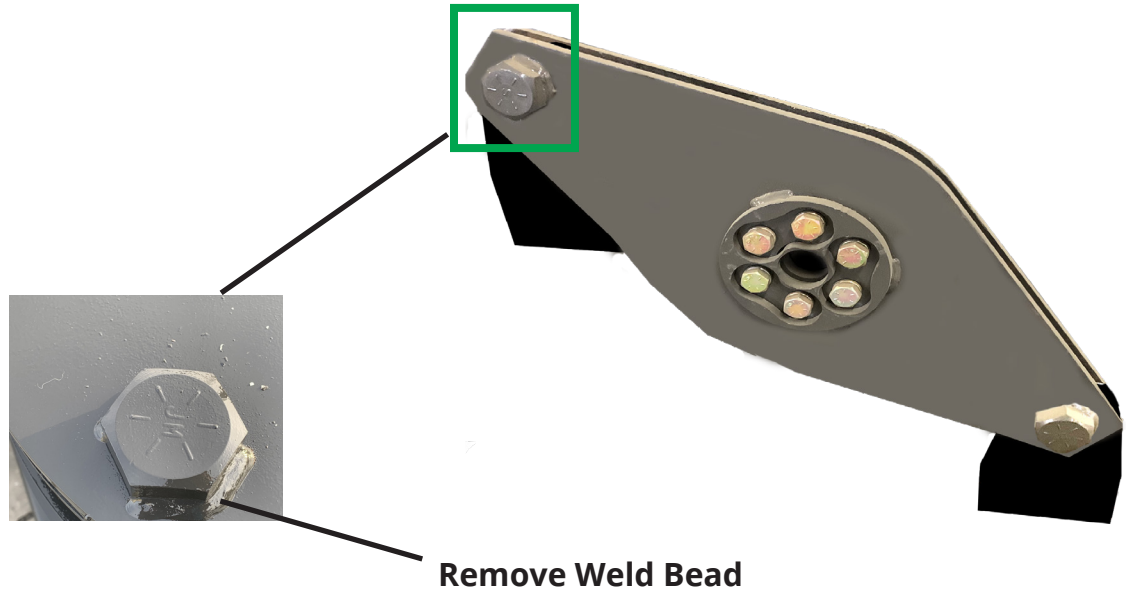

Figure 4.6a - Blade Holder Bolt Weld Bead Removal

Blade Sharpening Notes

1. Sharpen cutter blades with the appropriate tool.
2. Be careful not to overheat the blade steel causing the blade material to become brittle and prone to early failure.
3. Grind each blade to the similar shape and size so as to not create a set of mismatched blades.
4. ALWAYS sharpen or replace cutter blades as set.
5. NEVER mix and match used blades with new blades as they will cause the brush cutter to be unbalanced and result in a vibration that may cause damage to other brush cutter parts.

Blade Installation Procedure

1. Remove the old weld bead to ensure a flat smooth surface for new bolt head to mate to.
2. Place nut in the recessed hole on top of blade holder.
3. Insert new blade bolt up through the hole in the blade holder and tighten into the nut.

NOTICE

The blade bolt threads must extend beyond the nut, with the nut seated flush in the recessed hole.

4. Torque the blade bolt to the value shown in the torque table on page 37 of this manual.
5. Weld the outside of the bolt head as shown in Figure 4.7a left below.

NOTICE

DO NOT weld bolt head unless the nut is firmly seated into the recessed hole (see Figure 4.7b right below).

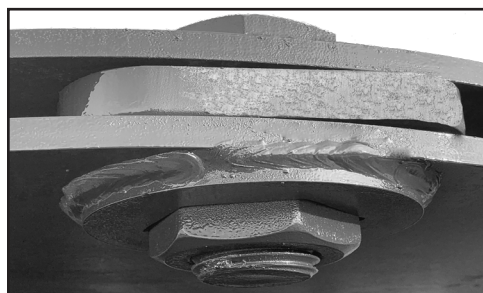

Figure 4.7a Bolt Head Bead Weld & Assembly



Figure 4.7b Bolt Thru Nut

4.8 Bearing Housing & Gearbox Maintenance

NOTICE

Maintenance procedures for the drive bearing housing and gear box motors require special tools and skills. **DO NOT** attempt to service the drive bearing housing or gear box motor unless you have the tools and skills to do so. Take your brush cutter to your local dealer to have these items serviced.

Swing Boom Cutter 17-30 GPM (SBCNS Models)

The SBCNS model has a bearing housing unit attached to a direct drive piston motor. Check the bearing housing oil level by:

1. The oil level in the drive bearing housing must be checked weekly. Refill with **85W-140 5EP** grade gear oil only.
2. **CHECK** the oil level by removing the oil filler plug and oil breather plug. The oil level should be at the bottom of the breather plug.

Oil Breather
Oil Filler Plug



Swing Boom Cutter 14-20 GPM (SBC Models)

The SBC model has a right-angle gearbox coupled to a hydraulic motor. Check the oil

1. **CHECK** the oil level by removing the oil filler plug. The oil level should be at mid height of the input spline.
2. If low, add **85W-140 5EP** grade gear oil. Check the oil level every week.



4.8 Bearing Housing & Gearbox Maintenance Cont.

NOTICE

The initial oil should be changed after 50 hours of operation under load. Subsequent oil changes should take place after every 1000 hours of operation.

Oil Change Procedure

1. Remove oil filler plugs.
2. Insert one end of a discharge hose into the gearbox (SBC model) or bearing housing (SBCNS model) oil filler ports. Then place the other end into an approved waste oil container.
3. Pump out the used oil from the bearing housing or gearbox motor.
4. Refill the bearing housing and gear box with **85W-140 5EP** grade gear oil. Remove breather plug on bearing housing and check if oil level is at bottom of hole. The gear box oil level should be at mid height of the input spline.

4.9 Shear Bolt Replacement

The SBC model (14-20 GPM) requires a shear bolt to protect the gearbox motor.

NOTICE

Only use a grade 2 shear bolt or shear pin as a replacement part. Using a hardened bolt may result in damage to the gearbox motor.

1. Remove the motor cover.
2. Remove the damaged shear bolt from the gearbox input spline.
3. Align the holes in the input spline with the motor coupler and insert new shear bolt.
4. Install shear bolt nut, and tighten.



4.10 Hydraulic Flow Diagram

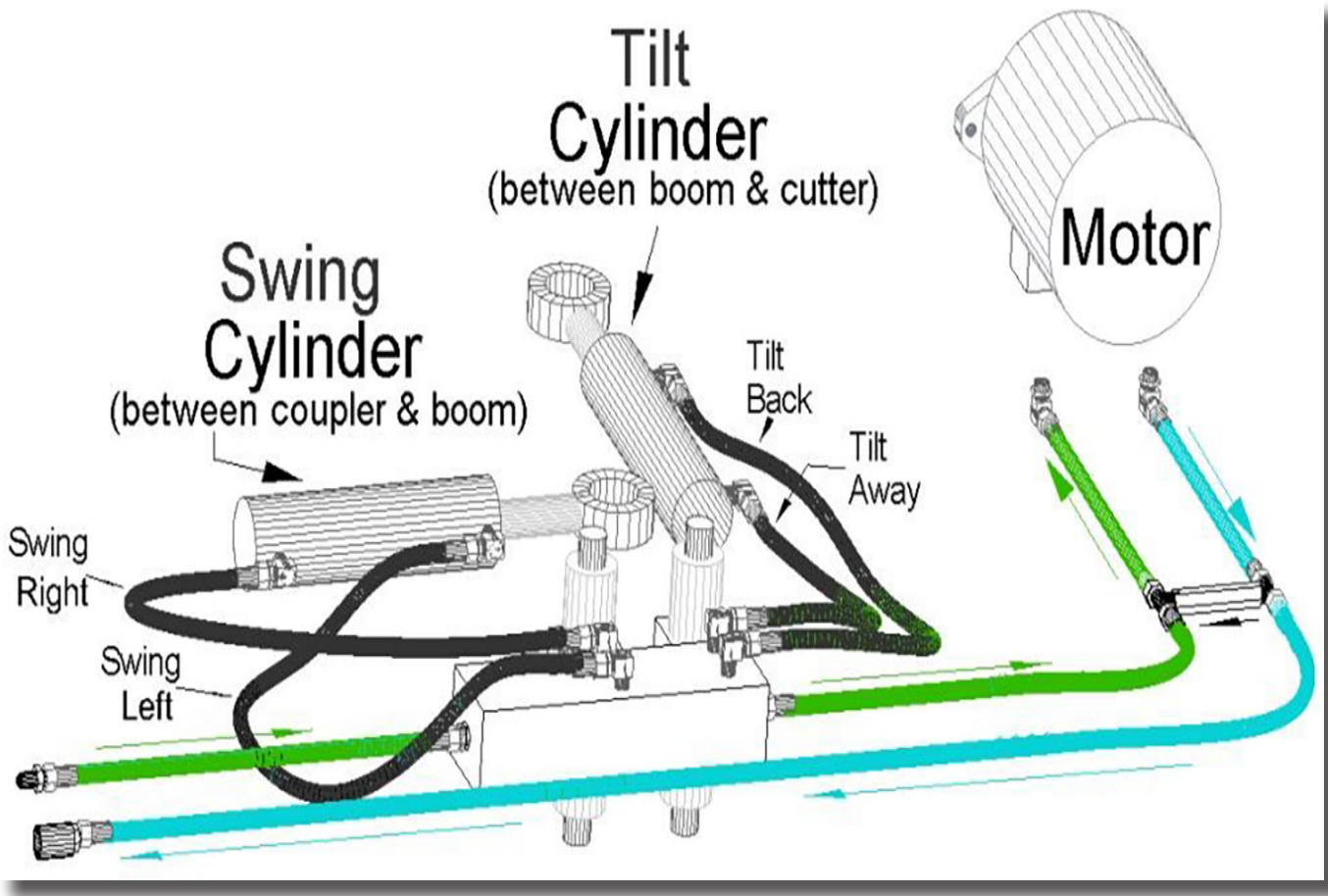

4.11 Torque Values Table

TORQUE VALUES SAE GRADE 8		
	DRY lb-ft	LUBRICATED lb-ft
1/4"	12	9
5/16"	24	18
3/8"	45	35
1/2"	110	80
3/4"	380	280
7/8"	600	450
1"	910	680

SECTION 5

TROUBLESHOOTING

5.1 Troubleshooting Chart

Problem	Cause	Solution
Cutter “bogs” down	<ol style="list-style-type: none">1. Cutter deck is not level causing material to “ball” under deck.2. Dull blades3. Ground speed too fast4. Cutter speed too slow	<ol style="list-style-type: none">1. See leveling tips on page 24.2. Remove and sharpen blades.3. Reduce your speed.4. Increase engine RPMs.
Vibration felt when running cutter.	<ol style="list-style-type: none">1. Cutter blades are unbalanced, missing or loose.2. Blade holder is damaged.3. Gearbox loose on cutter deck.4. Cutting height is set too low.	<ol style="list-style-type: none">1. Replace cutter blades with a properly balanced set.2. Replace blade holder.3. Tighten & torque gearbox mounting bolts.4. Raise cutter height.
Cutter blades break or dull too quickly.	<ol style="list-style-type: none">1. Excessive shock loading to the blades when they contact solid objects.	<ol style="list-style-type: none">1. Avoid hitting solid objects (rock, steel pipes, large tree stumps, etc.)2. Raise cutter deck to clear rocky surfaces.
Hydraulic oil level goes down during operation.	<ol style="list-style-type: none">1. Broken hydraulic hose line on brush cutter.2. Leak in the prime mover’s hydraulic system.	<ol style="list-style-type: none">1. Investigate & repair leak. ⚠ CAUTION Wear eye protection and use a piece of cardboard when checking leaks to prevent severe injury to your skin caused by high pressure fluid injection.
Blades do not spin when flow is activated.	<ol style="list-style-type: none">1. No oil flow.2. Check valve failure.3. Hydraulic motor failure.4. Gearbox failure.5. Shearbolt failure.	<ol style="list-style-type: none">1. Check skid steer hydraulic circuitry.2. Replace check valve.3. Disconnect the drive chain between gearbox and motor then turn blade holder by hand. Motor failure is suspect if blade holder can be turned. Contact dealer for further instruction.
Blades turn, but cannot tilt or swing the cutter.	<ol style="list-style-type: none">1. No electrical power to controller or solenoid valves.	<ol style="list-style-type: none">1. Check in-line circuit fuse & replace if necessary.2. Check connections at solenoid valves.

SECTION 6

SPECIFICATIONS

6.1 Specifications Chart

SWING BOOM CUTTER

MODEL NAME	MODEL #	WEIGHT (lb)	Min Skid Steer / CTL Lift Weight (lb) *	Min Skid Steer / CTL Lift Capacity (lb) *	Min Skid Steer / CTL Power	Gear Oil	Cut Capacity (inches)	Vertical Reach	Horizontal Reach	Cut Width
14-20 gpm										
SWING BOOM STANDARD BRUSH CUTTER	SBC	1,400	6,500	1,800	65 HP	85W-140 5EP	3	16 ft	8 ft	44 in
17-30 gpm										
SWING BOOM PISTON MOTOR BRUSH CUTTER	SBCNS	1,400	6,500	1,800	65 HP	85W-140 5EP	4	16 ft	8 ft	44 in

SECTION 7

PARTS INFORMATION

PARTS INFORMATION

Factory fresh parts specifically designed for your implement are readily available.

For hassle free service and to ensure you receive the correct parts for your implement, please provide your dealer with the following information:

Model Number	
Serial Number	
GPM Requirements	
Date of Owners Manual (Bottom Left Corner of Cover Page)	
Parts Diagram Page Number	
Part Description	
Reference #	
Quantity Desired	
Ship To Information	
Bill To / Payment Information	

Use Genuine Parts from Construction Implements Depot, Inc.

7.1 Parts Diagrams

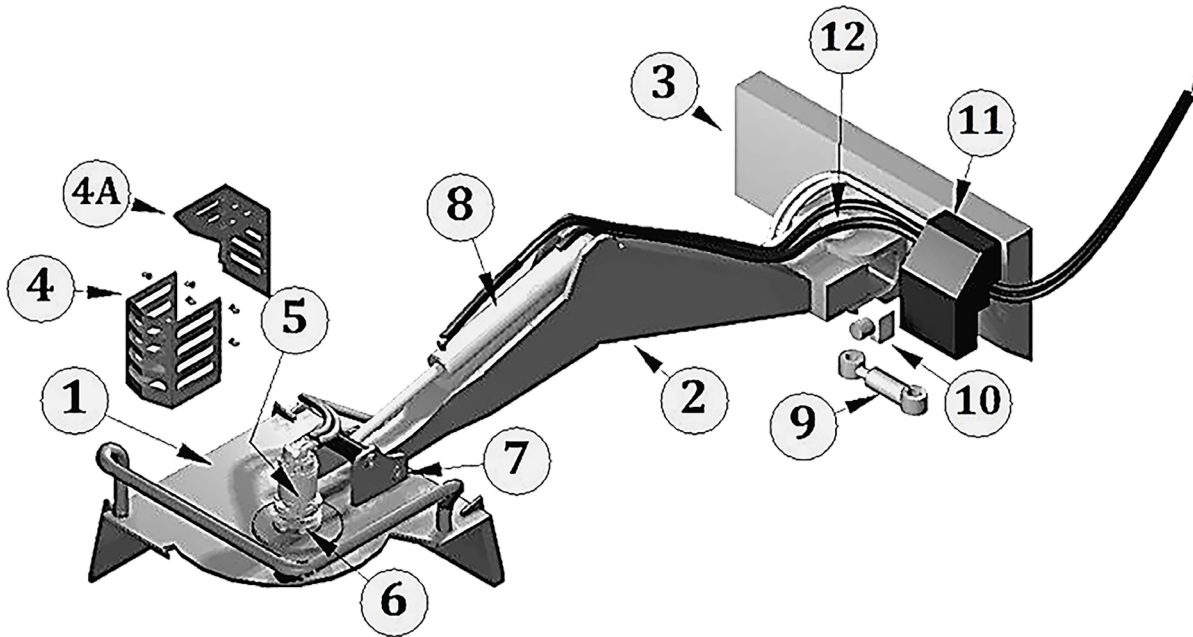

Ref. No	Part Description	Qty
1	Cutter Deck Weldment	1
2	Boom	1
3	Mounting Plate	1
4	Motor Guard	1
4A	Motor Cover	1
5	Hydraulic Motor	1
6	Drive Support	1
7	Pin	3
8	Tilt Cylinder	1
9	Swing Cylinder	1
10	Swing Bumper	1
11	Valve Cover	1
12	Swing Pivot Pin	1

7.1 Parts Diagrams Cont.

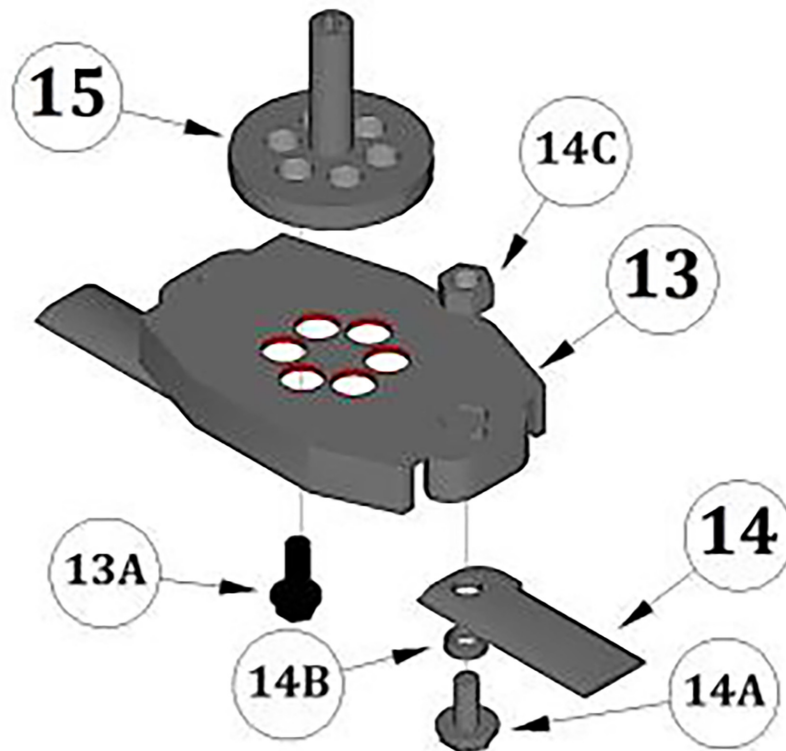

Ref. No	Part Description	Qty
13	Blade Holder	1
13A	Blade Holder Hardware Set	6
14	Blade Set	1
14A	Blade Bolts	6
14B	Spacer Washer	2
15	Output Shaft Assembly	1

7.1 Parts Diagrams Cont.

HYDRAULIC COMPONENTS

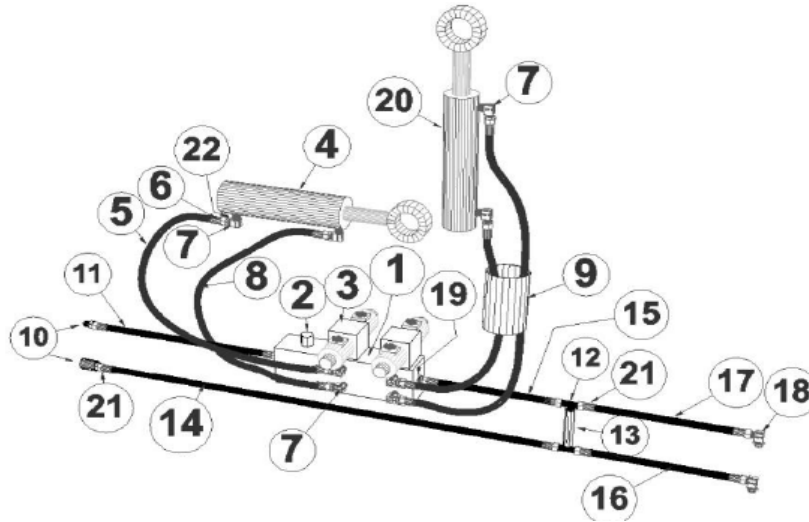

Ref. No	Part Description	Qty
1	Hydraulic Manifold	1
2	Flow Control	1
3	Control Valve	2
4	Swing Cylinder	1
5	3/8" Hose, 21" Long	1
6	Hose End 3/8"	8
7	Elbow 3/8"	8
8	3/8" Hose, 17" Long	1
9	Protective Sleeve Set : 93", 75", 60" Long (1/2", 3/8")	1
10	Flat Face Couplers	1
11	1/2" Hose, 72" Long	1
12	Tee	2
13	H-Valve	1
14	1/2" x 189" Hose	1
15	1/2" x 110" Hose	1
16	1/2" x 8" Hose	1
17	1/2" x 12" Hose	1
18	Elbow 1/2" (at hydraulic motor)	2
19	Straight Adapter 1/2"	2
20	Tilt Cylinder	1
21	1/2" Hose End	10

7.2 Electrical Diagrams

ELECTRICAL DIAGRAMS

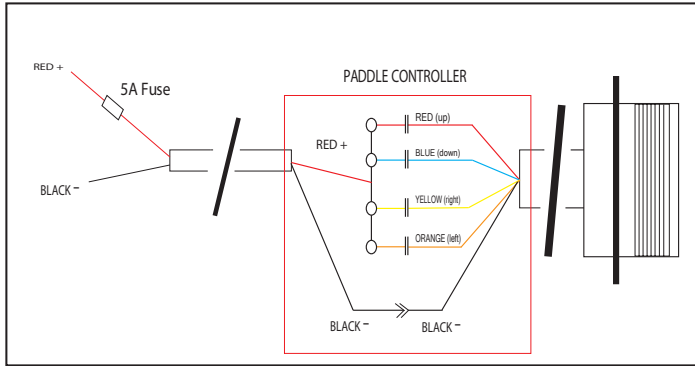

Valve Manifold on Cutter

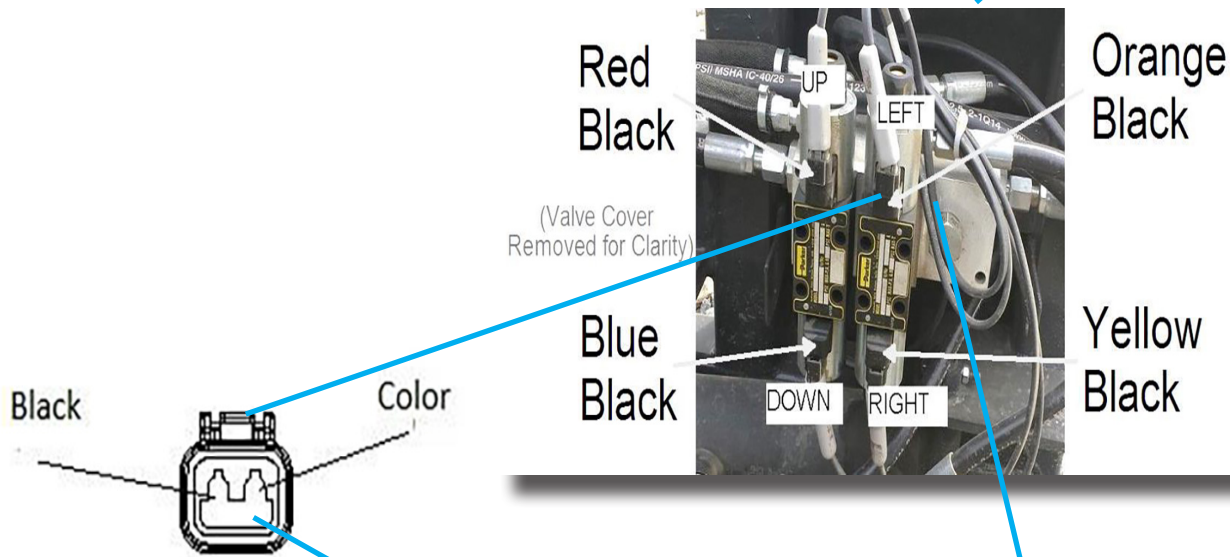

Attachment Harness



To bulkhead coupler on skid steer arm or paddle control cable

Paddle Controller and Cable



SECTION 8

WARRANTY INFORMATION

8.1 Warranty Information

Limited Warranty

Construction Implements Depot, Inc. products are warranted to be free from defects in workmanship or materials for a period of 12 months from the initial sale, lease or rental date.

Warranty Exclusions

This warranty does not cover normal wear items, including but not limited to: bearings, hoses, ground engaging parts such as teeth, blades, cutting edges, pilot bits, auger teeth and broom bristles. This warranty does not cover maintenance, service or adjustments. This warranty does not cover damage due to misuse, negligence, accidents, improper maintenance or modifications of this product. This warranty is void if any components have been disassembled, i.e., pumps, gear boxes or motors. Specially modified attachments built by CID X-treme Attachments to meet your customers' needs shall not be warranted by Construction Implement Depot, Inc. This warranty does not cover replacement parts not supplied by CID, Inc.

Warranty Statement

Our obligation under this Limited Warranty shall be solely limited to repairing or replacing any part (see non-covered items above) free of charge that, according to our judgment, show evidence of a defect in quality of workmanship or materials for the stated 12 month warranty period. All defective parts must be routed directly to CID, Inc. with freight or delivery charges to be prepaid. This limited warranty shall not be interpreted to render CID, Inc. liable for any injury or damage to persons, businesses or property of any kind nor expenses or losses incurred for labor, supplies, substitute machinery rental or for any other reason. Repair or replacement parts are subject to the supply conditions at the time of repair or replacements, which may directly affect our ability to obtain material and/or replacement parts. CID, Inc. reserves the right to make improvements in design or changes in specifications at any time without incurring any obligations to owners of previously purchased products. No one but CID, Inc. is allowed to alter, modify or enlarge this warranty nor the exclusions, limitations and reservation at any time.

8.1 Warranty Information

Warranty Service Procedure

RGA (Returning Goods Authorization) Policy:

If repairs are required, CID must obtain an RGA number from the manufacturer of the defective part and proof of purchase. RGA and services are rendered by CID only. Any responsibility of shipping costs on any item returned for repair is at the discretion of CID. All returned parts must have:

1. A legible RGA number written on the outside of the package.
2. A Service Request Form.
3. The defective part.

RGA numbers are only valid for 30 days from the date of issue. All shipped replacement parts will require a PO number from the original CID Customer. If the defective part is rendered non-warranty, the PO number will be invoiced for the replacement. Should you have any problems with your attachment, please follow the following procedures to obtain service.

1. Call the Warranty Department at (336) 859-2002 ext 215. You will need to provide the model and serial number of the defective item(s), a description of the problem and have photographs available.
2. Upon a warranted issue, visit www.cidattachments.com, click on the warranty tab, and fill in the warranty information. CID will retain an RGA number from the manufacturer of the defective part. If all the information above is fulfilled the manufacturer will issue an RGA number.
3. Obtain a PO number from the original CID customer. PO numbers will be invoiced in the event the defective part(s) is un-warranted
4. CID will ship a replacement part with a Service Request Form and RGA #. There will be a call tag with the Manufacturer's address and instructions for returning the defective part.
5. Once the defective part is warranted by the manufacturer, CID will be issued a credit and the PO number will be void.
6. In the event the manufacturer renders that the attachment be returned to CID for repair, CID will make arrangements for pickup and return. Repairs will be performed by CID qualified technicians. Non-warranted issues will be discussed and repairs will be performed upon agreement of the owner, and payment for parts and labor will be issued.

SECTION 9

MAINTENANCE LOG

MAINTENANCE LOG

Use this log sheet to document all routine maintenance and repair services performed on this machine.

DESCRIPTION OF MAINTENANCE	SERVICED BY	DATE

MAINTENANCE LOG

Use this log sheet to document all routine maintenance and repair services performed on this machine.

DESCRIPTION OF MAINTENANCE	SERVICED BY	DATE

SAFETY ACKNOWLEDGEMENT FORM

ATTENTION ALL OPERATORS: Print your name, sign and date in the boxes below to acknowledge that you have read and fully understand the safety instructions presented in this manual, and have been trained on how to safely operate this attachment.

OPERATOR NAME	SIGNATURE	DATE

SAFETY ACKNOWLEDGEMENT FORM

ATTN ALL OPERATORS: Print your name, sign and date in the boxes below to acknowledge that you have read and fully understand the safety instructions presented in this manual, and have been trained on how to safely operate this attachment.

OPERATOR NAME	SIGNATURE	DATE

SAFETY ACKNOWLEDGEMENT FORM

ATTENTION ALL OPERATORS: Print your name, sign and date in the boxes below to acknowledge that you have read and fully understand the safety instructions presented in this manual, and have been trained on how to safely operate this attachment.

OPERATOR NAME

SIGNATURE

DATE



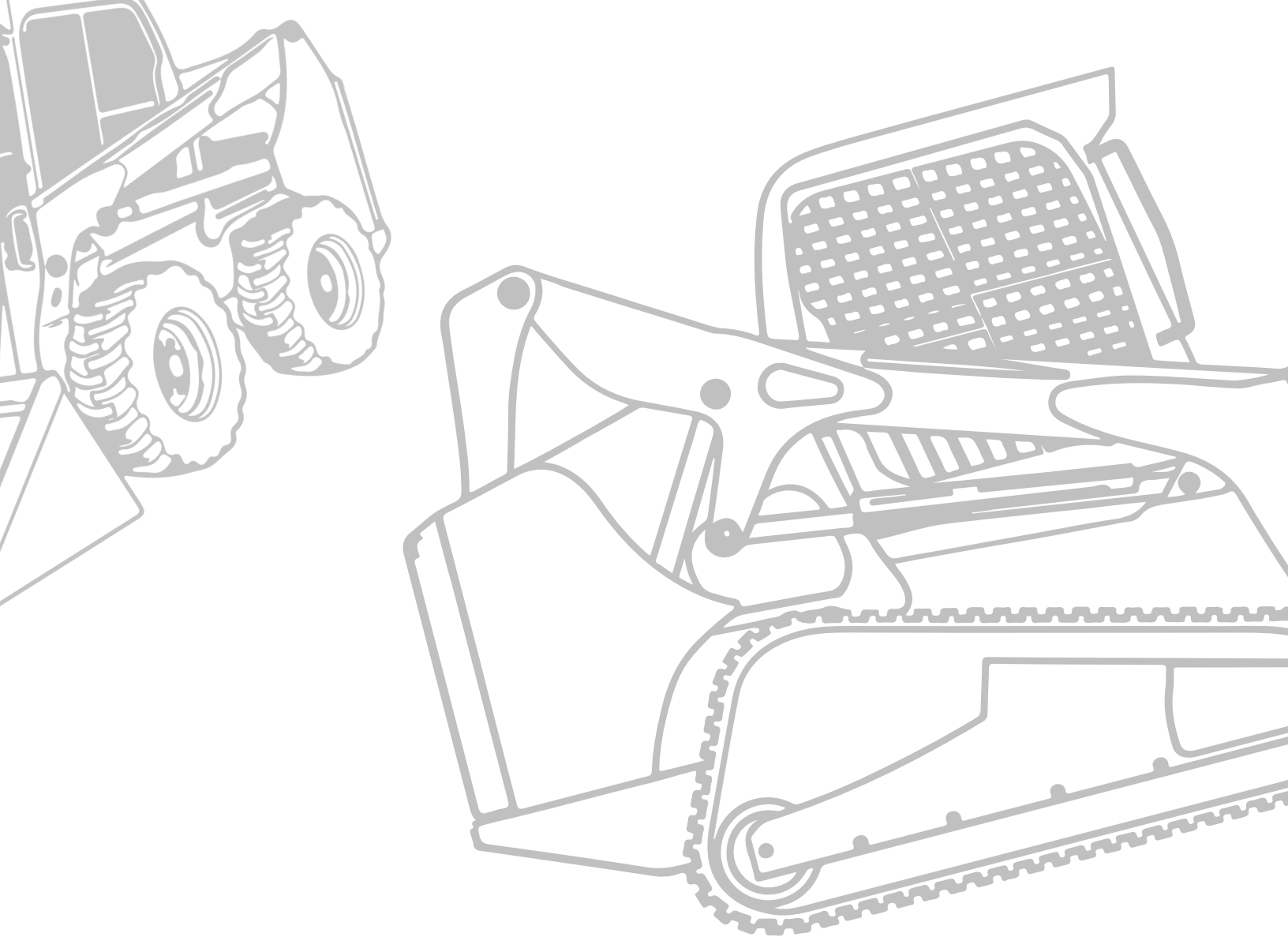

1248 N. Main Street | P.O. Box 1230 | Denton, NC 27239

Phone: 336.859.2002 | Fax: 336.859.0800

sales@cidattachments.com

www.cidattachments.com